

viewmaster^x

Warranty

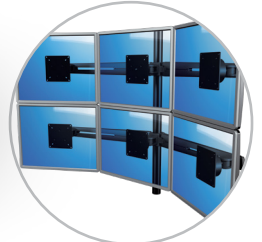

53.633

Viewmaster multi-monitor system - desk 633

This model mounts a total of 6 monitors. Like on all other winged multi-monitor systems, each monitor can be adjusted individually. Cable management in the wings tidies up all cables, resulting in an impressive, curved monitoring workstation.

- Stepless height adjustment
- For 6 monitors
- Cable clips and loop ties included
- Die-cast aluminium parts
- VESA MIS-D 75 x 75/100 x 100 mm compatible
- Monitor: tilt +55°/-55°, swivel +90°/-90°, rotate 360°
- Weight capacity max. 12 kg (26,5 lb) per monitor
- Desk mount not included
- Monitor size limit: width 440 mm (17,3") - height 428 mm (16,8")
- Due to excellent stability also suitable for touchscreens

dataflex^x

feeling at work

viewmaster

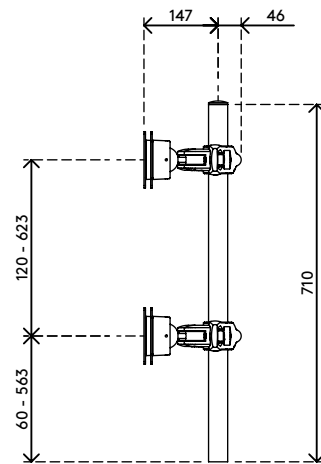
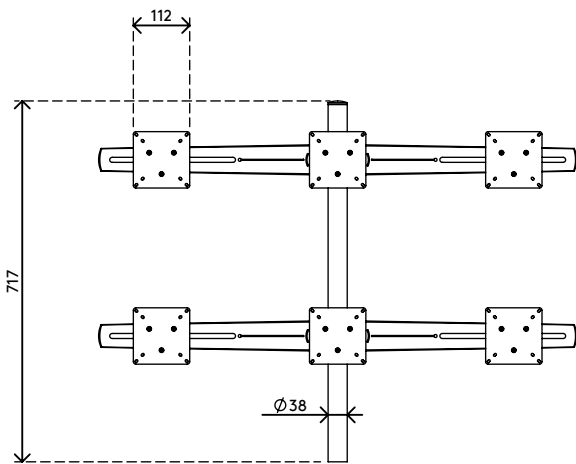
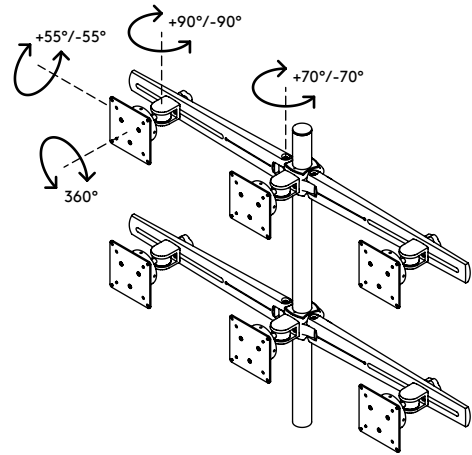
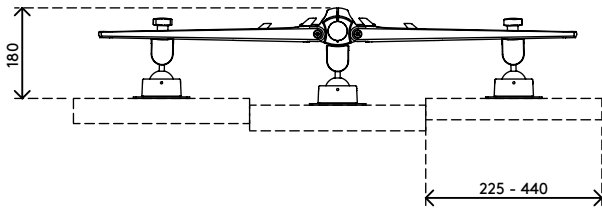

+55°/-55°

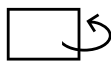

+90°/-90°



360°



440 mm (17,3")



428 mm (16,9")



75 x 75/100 x 100



(6x) 12 kg (26,5 lb)

Viewmaster multi-monitor system - desk 633

2020/10/06

53.633

 740 x 395 x 120 mm

 1 pcs

 black

 11,47 kg

 805410536336