

# viewmaster<sup>x</sup>

Warranty

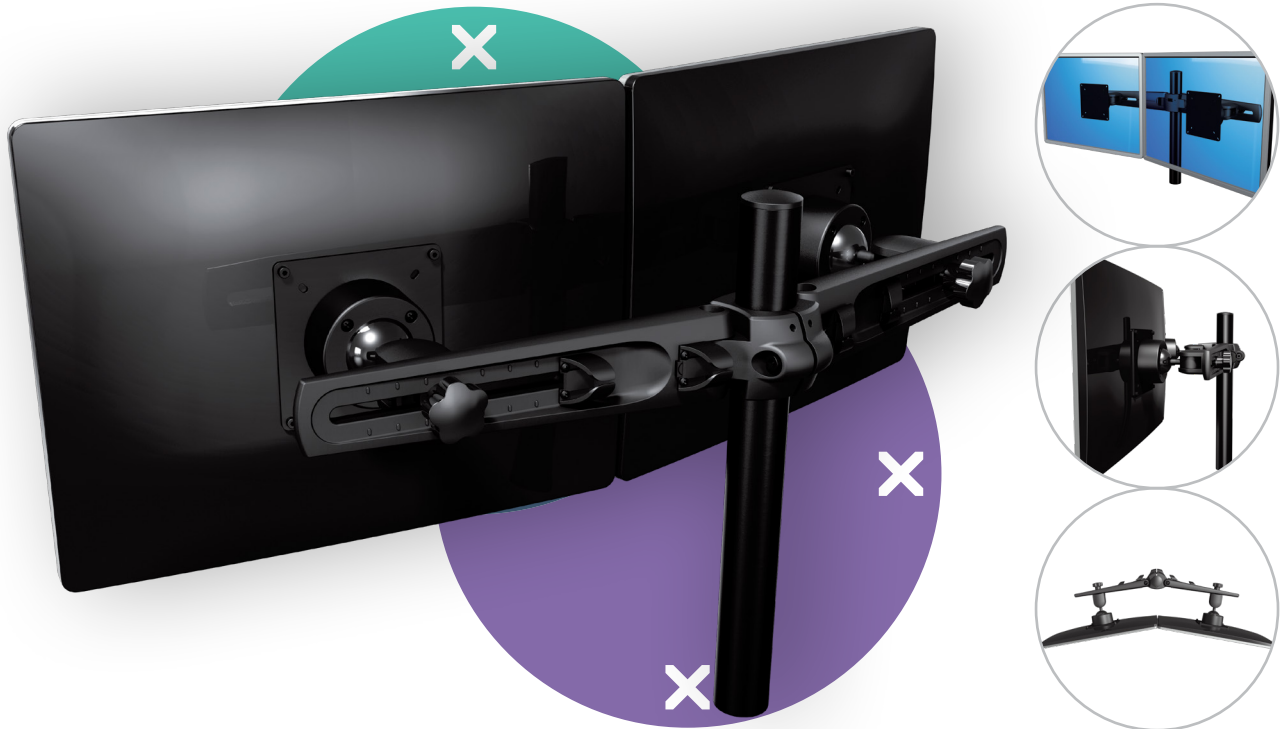

53.233

## Viewmaster multi-monitor system - desk 233

This model mounts 2 monitors. Like on all other winged multi-monitor systems, each monitor can be adjusted individually. Cable management in the wings tidies up all cables, resulting in an impressive set-up that can be either flat or curved.







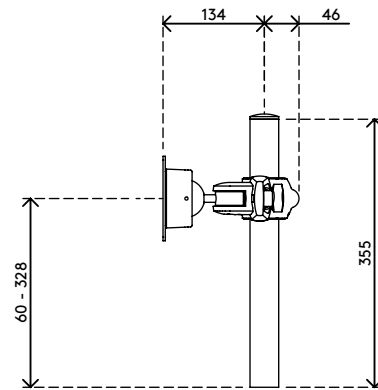
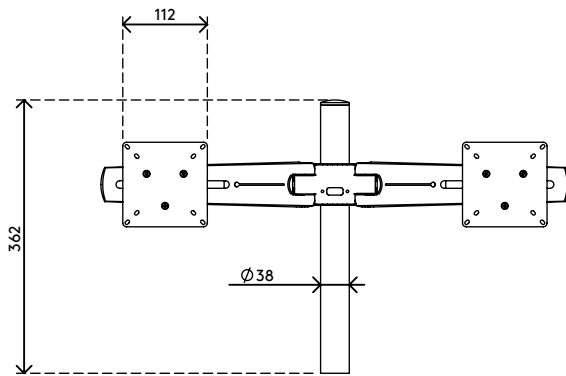
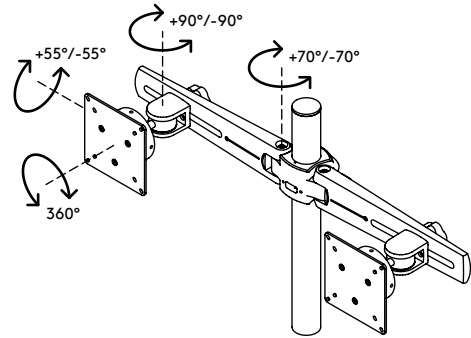
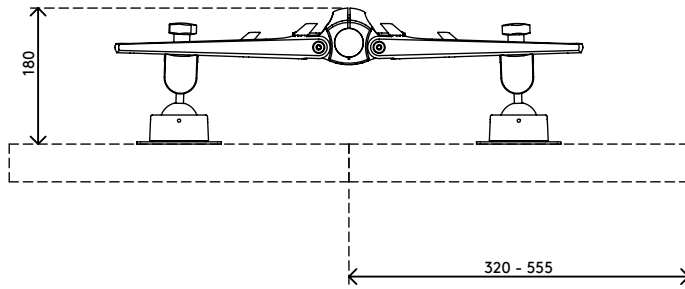

- Stepless height adjustment
- For 2 monitors
- Cable clips and loop ties included
- Die-cast aluminium parts
- VESA MIS-D 75 x 75/100 x 100 mm compatible
- Monitor: tilt +55°/-55°, swivel +90°/-90°, rotate 360°
- Weight capacity max. 12 kg (26,5 lb) per monitor
- Desk mount not included
- Monitor size limit: width 555 mm (21,9") - height 618 mm (24,3")
- Due to excellent stability also suitable for touchscreens

**dataflex**<sup>x</sup>

feeling at work

# viewmaster x



-   
 268 mm (10,6")
-   
 +55°/-55°
-   
 +90°/-90°
-   
 360°
-   
 555 mm (21,8")
-   
 618 mm (24,3")
-   
 75 x 75/100 x 100
-   
 (2x) 12 kg (26,5 lb)

**Viewmaster multi-monitor system - desk 233**

2020/10/06

# 53.233

 535 x 250 x 155 mm

 1 pcs

 black

 4,675 kg

 805410532338